

You have the

POWER!



A Guide to Lowering Utility Costs by Using Energy Wisely

One of the best things about being a member of an electric cooperative is that you have the power to directly affect what you pay for energy.

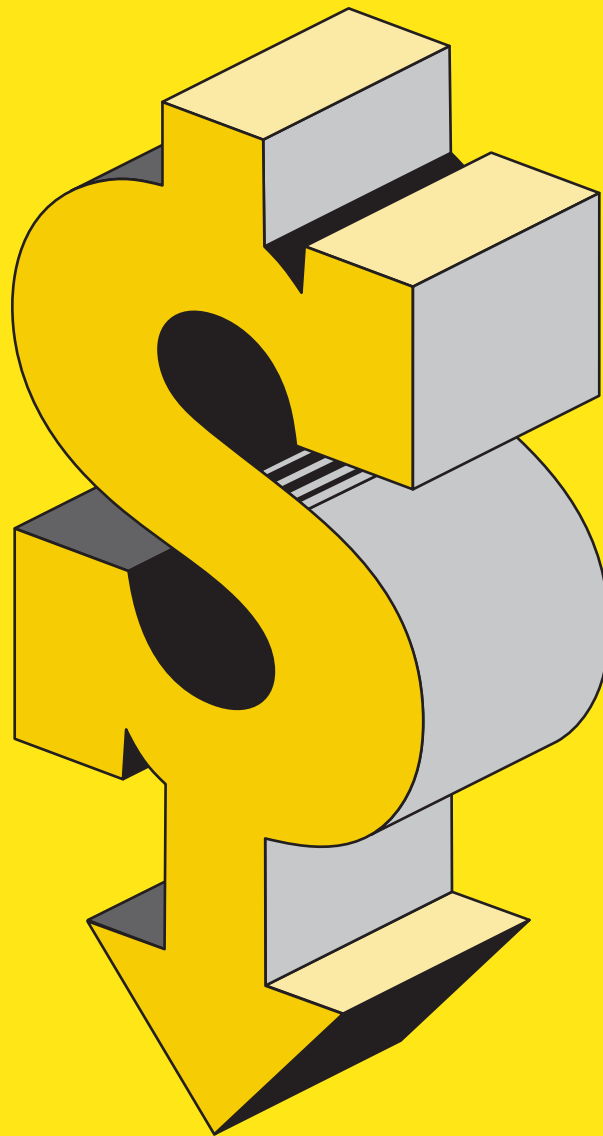

When all co-op members make the effort to manage their energy use more effectively, the result is that the co-op ultimately doesn't need to buy as much energy to serve members' needs. That means that the cost of energy comes down for everyone in the co-op. Not only that, you'll also be helping to reduce your co-op's dependence on power generated by fossil fuels. That means cleaner air for everyone.

This guide is designed to give you all the information you need to manage energy effectively in your home or business. You'll learn how to make the most efficient use of energy in everything from heating and cooling systems to lighting and appliances. There are tips on saving energy in small ways every day, as well as detailed information about taking energy efficiency into account when it's time to replace major appliances or if you're undertaking a major home renovation.

Remember, doing all you can to effectively manage energy use will have a direct impact on your energy costs and quality of life. As a co-op member, that's the kind of power you have.

1	Heating and Cooling	2
2	Appliances	7
3	Home Electronics	10
4	Lighting	11
5	Pools and Spas	12

1 Heating and Cooling

Because you spend the largest portion of your energy dollars staying warm or cool, you'll save the most on energy by taking steps to use your heating and cooling systems more efficiently. Follow the tips on the next few pages, and you can reduce your heating and cooling bills by as much as 50 percent.

Heating and Cooling: The Biggest Piece of the Energy Pie

Heating & cooling 44%

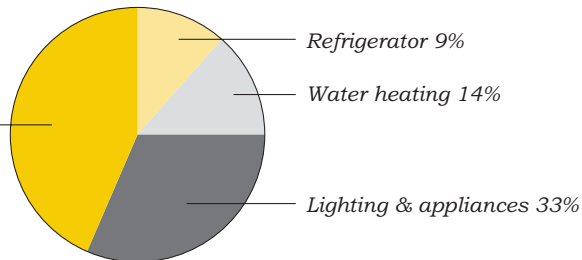

Adapted from the U.S. Department of Energy's Energy Savers booklet, available at www.eere.energy.gov.

Simple Steps You Can Take to Save on Heating and Cooling

There are many simple, low-cost (or no-cost) things you can do every day to reduce your use of energy for heating and cooling, such as setting your thermostat appropriately or using ceiling fans to circulate heated or cooled air more effectively.

Set Your Thermostat on "Savings"

The single best way to reduce heating and cooling costs is to set your thermostat at 78° or higher in summer and 68° or lower in winter. If you're keeping your thermostat at 72° in the summer, consider this: According to the U.S. Department of Energy, raising that setting to 78° could save you up to 47 percent on cooling costs.

You'll save additionally by greater adjustments to your thermostat (higher in summer, lower in winter) while you are away from home or asleep. When you return or wake up, don't set it at an unnaturally lower or higher setting to try to cool or heat the house faster. That doesn't work; it just cools or heats the house more than you need, which uses more energy.

Do keep in mind that if you have an infant or an older person living in your home, they may require cooler or warmer temperatures to stay healthy. Use your common sense.

fact → Every degree above 78 that you set your thermostat in summer will save up to 3 percent on cooling costs.

Consider the Alternatives

The principle is simple: It's a lot cheaper to move air around than it is to heat or cool it. With that in mind, consider these ways to stay cool in summer and warm in winter without depending entirely on your central system.

In the heat of the summer, use fans to circulate cooled air while you keep the thermostat at a higher setting.

If you live in a part of the state with low humidity, consider an evaporative cooler as an alternative to central air conditioning. Evaporative coolers use water evaporation to cool the air and a fan to circulate it.

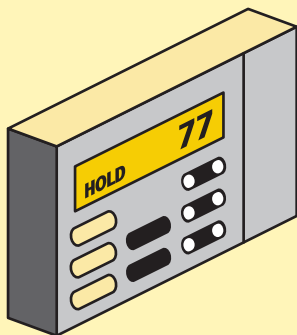

Programmable Thermostats

For maximum energy efficiency in heating or cooling, use a programmable thermostat to automatically adjust the setting when you leave the house or go to bed and then turn it back to normal when you return or wake up. Programmable thermostats range in cost from \$45–\$100+, but can easily pay for themselves in energy savings.

There are many options for heating and cooling your home. During temperate weather, consider leaving windows and doors open if you feel safe doing so. Use floor and ceiling fans to circulate air. For maximum cooling, use the central system supplemented by fans, and lower window shades to keep out the sun. For maximum heating, use the central system supplemented by fans, and open shades to take advantage of the sun's rays. ▶

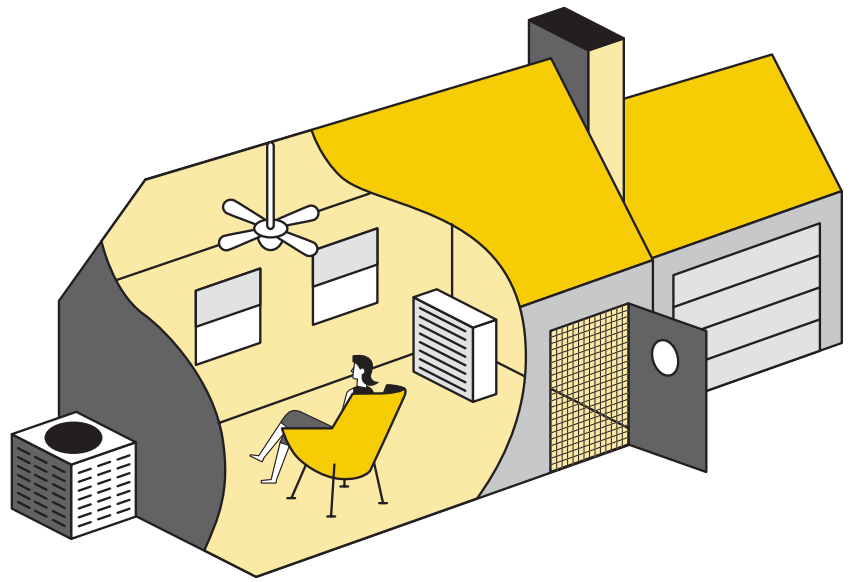

In spring and fall, when it's not particularly hot or cold, a whole house fan can be an excellent alternative to your central system. Installed in the ceiling, a whole house fan draws outdoor air inside to cool the house.

tip → Use pleated instead of mesh filters in your central air-and-heat system for better filtration.

Get Your Ducts in a Row

Are the air ducts in your home delivering all the warmth or cooling your system is generating—or are they losing it due to poor performance? Here's what you can do to make sure your ducts are working properly and delivering the conditioned air you're paying for.

Be sure your ducts aren't leaking. You or your service professional will be looking for:

- Obvious holes in the ducts.
- Dirty spots on the duct insulation and around air vents.
- Areas where connections have become separated.

If you find only a few problem areas and you're a do-it-yourselfer, you can repair and seal them with duct tape. Just be sure to use tape with the Underwriters Laboratories (UL) logo on it to avoid tape degradation or cracking over time. However, if you find that your ductwork is very poorly insulated or has extensive leakage problems, call a service professional.

tip → In winter, set your ceiling fan to turn clockwise to send warm air downward into the room. In summer, set it to turn counter-clockwise to circulate cool air through the room.

Attic Insulation

- Measure carefully to be sure you buy the correct amount of insulation.
- Get the right stuff. Choose batts or blankets to fit between joists, and use rolls or blankets on the attic floor.
- Install a vapor barrier of thick plastic sheeting if you choose insulation in the form of "faced" batts or blankets.
- Follow the product instructions and wear proper protective gear when installing insulation.
- Have attic vents installed along the ceiling cavity; this will ensure proper airflow from soffit to attic to control moisture and maintain the insulating power.

In a multi-story building, lightweight fencing (left) or wire lacing (right) retains insulation between floors. ▼

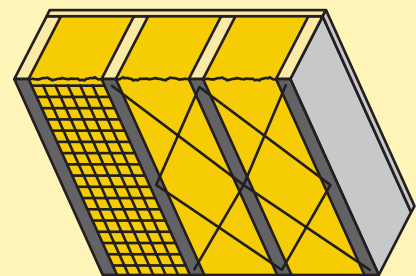

Regular System Maintenance

Like any other mechanical device, a central heating and cooling system will only work well if it's regularly maintained. That means keeping the system properly "tuned" with regular professional checkups, frequent filter cleanings or replacements, and periodic observation of both the inside and outside units.

Home Improvements That Can Save You Plenty

Energy-related home improvements may not be as inexpensive as buying a fan or as simple as scheduling a system checkup, but they can be well worth the expense or time they require.

Save With a Heat Pump

Like standard systems, heat pumps can meet your heating and cooling needs in one unit. The difference is that a heat pump will heat for significantly less cost than a typical electric resistance-heating unit. There are two types of heat pumps available today.

- Air-source heat pumps draw heat from the air outside to heat your home in winter, and expel heat outside to cool your home in summer. An air-source heat pump may reduce your heating costs by up to 50 percent if you convert from an electric furnace to an all-electric air-source heat pump. Generally, the colder it gets where you are, the less the savings, since the colder the air outside, the more difficult it is to extract heat from it.
- Ground-source heat pumps (also known as geothermal or earth-energy systems) make use of the earth's ability to store natural heat. They pump heat from deep in the earth into your home rather than taking it from the air. A ground-source heat pump may cost more than a conventional system, but the energy savings could pay for the unit in three to five years.

Be Good to the Planet and Your Pocketbook: Go Solar

Using passive solar energy to heat and cool your home can cut your heating costs by more than 50 percent and help reduce your cooling costs, too. If you're building a new home or doing a major renovation of your existing home, consider passive solar techniques such as:

- Placing larger, insulated windows on south-facing walls for more efficient heating.
- Improving heat transfer by locating thermal mass, such as a concrete slab floor or heat-absorbing wall, close to windows.
- Using reflective coatings on windows, exterior walls and roof to keep out heat in summer.
- Installing strategically designed overhangs to shade the house from summer sun.

Keep the Air Inside Where It Belongs

If your heating and cooling dollars are going out the window due to air leaks in your house, you need to caulk, weather-strip and insulate.

Caulking, or filling cracks and gaps in your home will eliminate air leakage around doors and windows as well as in areas where plumbing, ducting or electrical wiring penetrates the house. Weather-stripping is also useful around doors and windows that leak air.

Insulation creates a barrier of resistance to keep heat from escaping in winter or coming in during summer. The "R-factor" assigned to different types of insulation refers to the level of resistance. Different R-factor ratings are appropriate for different parts of the state, so check with your co-op and a local insulation dealer to see what's right for you.

The best place to start insulating is the attic. That's because heat tends to rise and is therefore more likely to be lost or gained through the highest part of the house. The attic is also one of the easiest places to install insulation.

Where Does the Air Go?

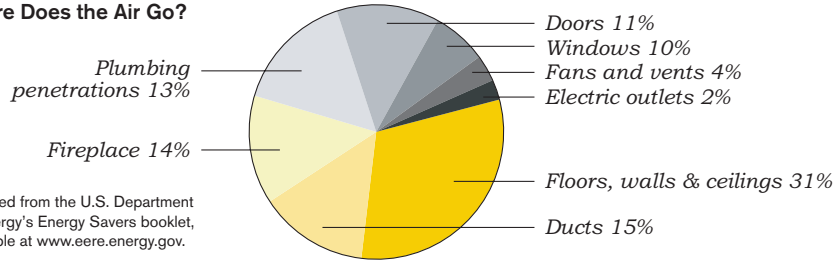

Adapted from the U.S. Department of Energy's Energy Savers booklet, available at www.eere.energy.gov.

More than 600,000 cubic feet of air passes through the older Texas house daily. That's enough to fill three Goodyear blimps every 24 hours. ▶

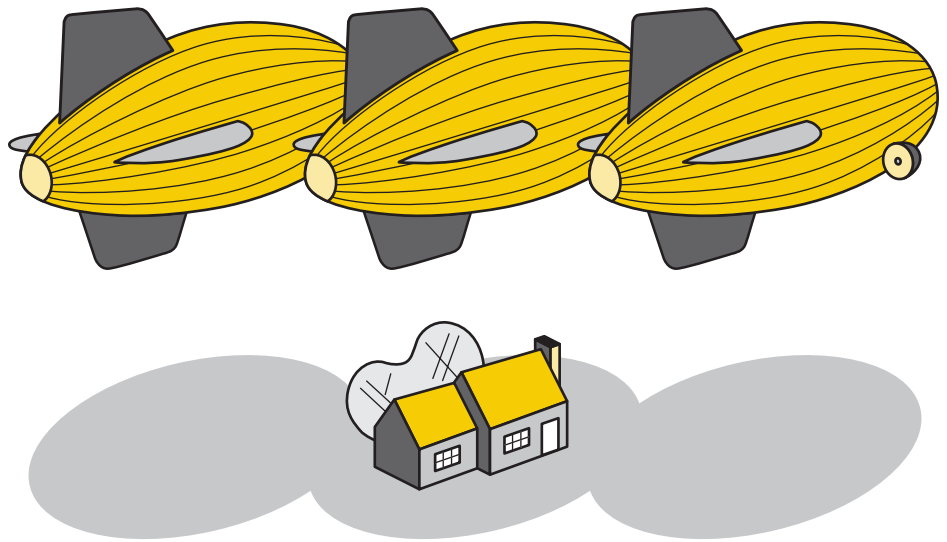

Let the Sunshine In (But Only in Winter)

The U.S. Department of Energy estimates that one-fourth of the energy used to cool and heat your home is lost through windows.

Things you can do inside:

- Use lined draperies, opaque roller shades or special thermal shades on windows.
- Choose carpeting over fibrous padding for optimal heat gain or loss.
- Use fabric or woven wall coverings.

Things you can do outside your home to reduce energy loss:

- Consider installing storm windows and double-pane windows, which are at least twice as effective as single-pane windows.
- When you do spring planting, choose deciduous greenery for the south and west sides of your house that will leaf out and block the sun in summer—but lose its leaves and let in warming rays in winter.
- Consider the new solar panels that can absorb and dissipate up to 70 percent of the sun's heat and glare before it reaches the windows. They are easy to install and can be removed in winter.

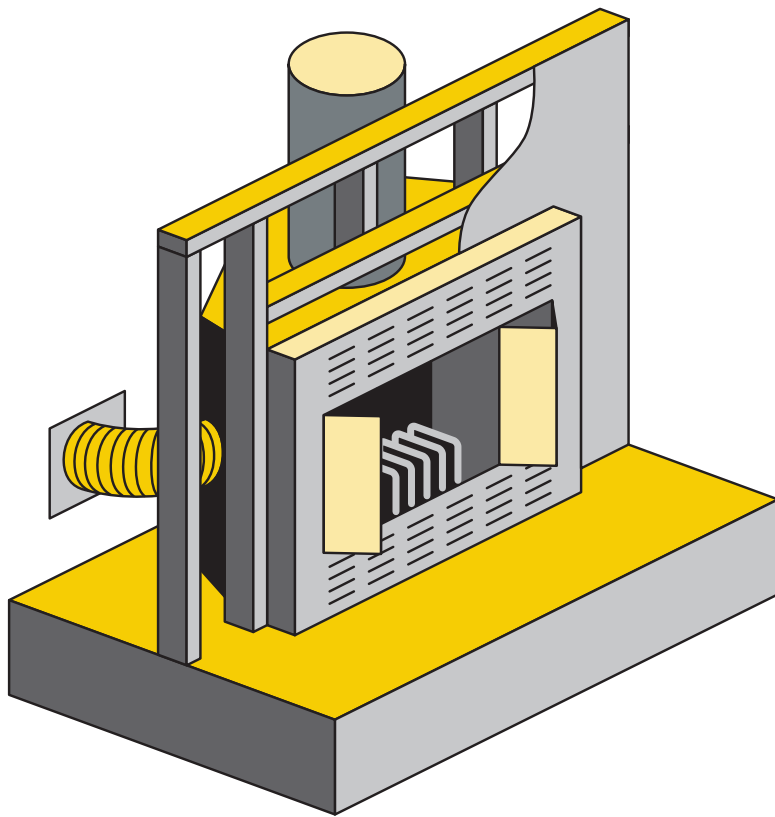

Keep your fireplace damper closed unless a fire is going. Leaving the damper open is like throwing open a 48-inch window. The damper should be well sealed. It's best to cover the firebox opening with metal or glass doors, which will restrict the amount of heated air drawn from the house. ◀

Keep the Home Fires Burning Efficiently

As much as 30 percent of your conditioned air could vanish right up the chimney. That's because a fireplace needs air to keep the fire burning—and it gets that air from inside your home, where you've already paid to make the air warm. Take these steps to improve fireplace efficiency:

- Cover the firebox opening with tight-fitting metal or glass doors.
- Have a tight-fitting flue damper with an accessible handle; keep the damper open when the fireplace is in use and closed when it's not.
- Use a combustion air intake with a tight-fitting damper to draw air from outside into the firebox.
- Keep ash box clean, especially if outside, to provide air source.
- Use well-aged firewood, which burns hotter and cleaner.
- Caulk around the hearth.
- Plug and seal the chimney flues of unused fireplaces.

Stay Out of Hot Water

Water heating accounts for a sizable part of your energy bill—about 14 percent. Fortunately, there are a number of things you can do to ensure that you have plenty of hot water without wasting energy in the process.

Start by thinking of ways to use less hot water. Take showers instead of tub baths, for example. Or install low-flow showerheads and faucets. You can also reduce your energy consumption for water heating by turning down the water heater thermostat. (A setting of 120 degrees will provide a comfortable water temperature for most uses.) And you can insulate your hot-water storage tanks and pipes to reduce heat loss.

U.S. Hot Water Usage

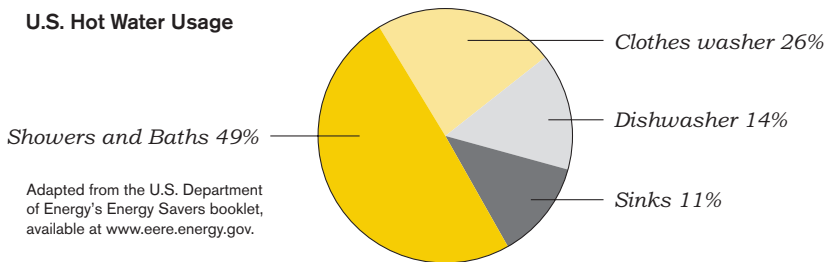

Adapted from the U.S. Department of Energy's Energy Savers booklet, available at www.eere.energy.gov.

SEER: We Spell It Out for You

When buying a new central system or heat pump, check the unit's SEER (Seasonal Energy Efficiency Ratio) number. The higher the SEER, the more efficient the unit's performance.

Heating and Cooling in a Nutshell

- Set the thermostat at 78 degrees in summer, 68 degrees in winter.
- Consider alternatives such as fans to take the load off your central system.
- Have your system serviced regularly for efficient operation.
- Clean or replace filters regularly.
- Keep ducts in good repair to avoid air leaks.
- Caulk, weather-strip and insulate.
- Install storm windows and double-pane windows.
- Landscape with plants that will block the sun in summer and let it in during winter.
- Choose window coverings, carpet and wall coverings with energy efficiency in mind.
- Take steps to minimize air loss through the fireplace.
- Lower the water heater thermostat to 120 degrees.

2 Appliances

The energy costs to operate everyday appliances such as refrigerators and freezers, ranges and ovens, washers and dryers, and dishwashers account for about 20 percent of your electric bill. You can reduce these costs by using appliances efficiently and by looking for high-efficiency choices when it's time to buy new ones.

Tips for Using Appliances Efficiently

Refrigerators and Freezers

Keep it clean. Regularly defrost models that aren't frost-free, and clean the condenser coils of your refrigerator three or four times a year.

Shut the door. Don't stand in front of an open fridge contemplating the contents. Decide what you need before you open the refrigerator, then get what you need and shut the door.

Fill the freezer. A freezer that's two-thirds to three-quarters full requires less energy to operate than an empty one. If you don't have enough food to fill the freezer, add some water-filled plastic milk cartons or soda bottles.

Test the seals. Fold a paper towel, shut the refrigerator door on it and then pull the towel out of the closed door. If there's no resistance, you probably need new seals around the door to keep the cold air in.

Maintain the right temperature. Optimum refrigerator temperature is 38 to 42 degrees. For the freezer, it's 0 degrees or higher (although not higher than the freezing point of 32 degrees, obviously).

Pay Attention to the EnergyGuide Label. It includes the estimated energy consumption in kWh on a scale with similar appliances and the estimated yearly operating cost based on the national average cost of electricity. ▼

Based on standard U.S. Government tests

ENERGYGUIDE

REFRIGERATOR
DEFROST TYPE: AUTOMATIC
MODEL(S): SR-0710
CAPACITY: 4.9 cubic ft.

Compare the Energy Use of this Refrigerator/
Freezer with Others Before You Buy.

This Model Uses 316 kWh/Year

Energy use (kWh/year) range of all similar models

Uses Least Energy	Uses Most Energy
303	436

THE ESTIMATED ANNUAL ENERGY CONSUMPTION OF THIS MODEL WAS NOT AVAILABLE AT THE TIME THE RANGE WAS PUBLISHED.

kWh/year (kilowatt-hours per year) is a measure of energy (electricity) use. Your utility company uses it to compute your bill. Only models with 4.5 TO 6.4 cubic feet and the above features are used in this scale.

Refrigerators using more energy cost more to operate. This model's estimated yearly operating cost is:

\$26

Based on a 2001 U.S. Government national average cost of 0.29¢ per kWh for electricity. Your actual operating cost will vary depending on your local utility rates and your use of the product.

Important: Removal of this label before consumer purchase violates the Federal Trade Commission's Appliance Labeling Rule (16 C.F.R. Part 305, Part No. 833640646000)

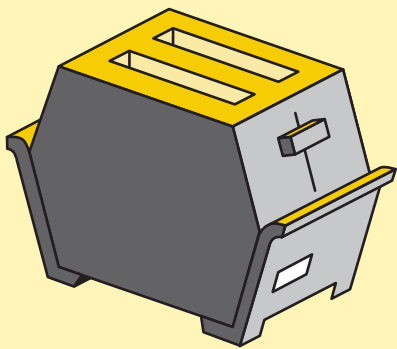

How Much Are You Paying to Run Your Appliances?

To determine how much electricity an appliance uses, follow these steps:

1. Find the wattage of the appliance. (It's usually listed on the serial number plate.)
2. Estimate the hours per month that you use the appliance.
3. Multiply the wattage by the hours of use per month. Divide the result by 1,000 to get your total monthly kilowatt-hour (kWh) usage for the appliance.
4. Figure out your average monthly cost per kWh by dividing your total monthly electric bill by the number of kWh used. (kWh used will be listed on the bill.)
5. Determine your monthly energy cost for the appliance by multiplying the kWh usage by your cost per kWh.

Electric Ranges and Ovens

Keep it covered. Use pan lids to retain the heat in the pan. Remember that water boiled in a covered pan comes to a boil faster.

Use the right pan. Don't waste energy by using a pan or pot that is too small for the burner, or that is too large or heavy for the amount or type of food you are cooking.

Turn off burners sooner. Because electric burners stay hot for a while after they're turned off, you can turn the burners off several minutes before the allotted cooking time. The food will finish cooking without using more electricity.

Preheat selectively. Baked goods may require a preheated oven to come out just right, but other foods don't. There's no need to preheat when you're cooking a main dish or heating a casserole.

Use heat-conducting cookware. Ceramic, glass and stainless-steel cookware conduct and retain heat better, which means that you can reduce the oven temperature by 25 degrees when you use them.

Close the door. The oven loses about 25 degrees of heat every time you open the door. Use a timer to gauge doneness instead of opening the oven door every few minutes to check.



A toaster oven uses a third to half as much energy as a full-sized oven, which makes it a great choice for small meals and snacks.

Washers and Dryers

Don't run small loads. Wait until you have enough laundry for a full, large load.

Sort by wash temperature. Use hot water only for whites and hard-to-clean items. Wash everything else in warm or cold water to save on water heating costs.

Pretreat stains. The more you can do to remove stains and heavy soil before you wash, the less likely you'll have to wash an item a second time.

Shorten the wash cycle. Cutting washing time from 15 to 7 1/2 minutes will save about 25 percent of the electricity needed to run the washer.

Fill the dryer. Don't waste electricity by drying just one or two items.

Dry heavy items separately. Dry heavy items like towels in a separate load from lighter-weight items that don't need as much drying time.

Don't over dry. Use the cool-down cycle to allow clothes to finish drying with the residual heat in the dryer. If your dryer has a moisture sensor that automatically shuts off the machine when clothes are dry, use it.

Install a vent/filter kit. This will allow you to vent clean, warm air from your clothes dryer into your home during winter, recycling heat that would otherwise be wasted.

Use a clothesline. Anytime you can dry clothes outside instead of in the dryer, do. That's free solar energy!

Clean Up With the Right Laundry Temperature

Water Temperature	Electricity Saved
Hot wash/warm rinse	0%
Hot wash/cold rinse	33%
Warm wash/warm rinse	33%
Warm wash/cold rinse	67%
Cold wash/cold rinse	100%

Dishwashers

Run a full load. Don't run your dishwasher when there are only a few items in it.

Shorten the cycle. Keep the dishwashing cycle as short as possible. Don't use a long "pots and pans" cycle if you're only washing plates, glasses and silverware.

Air-dry dishes. Skip the drying cycle to reduce the amount of electricity needed to run the dishwasher.

fact It takes less water to wash a load of dishes in the dishwasher than to wash them by hand—approximately 9.9 gallons compared to an average of 15.7 gallons.

Buying New? Put Energy Efficiency First

There's plenty of consumer information available to you today to help you make the most energy-efficient choices when purchasing new appliances. (See sample EnergyGuide label on page 7.)

tip When buying a new freezer, choose a chest-style freezer instead of an upright model. Chest-style freezers retain cold air better when the door is opened.

Front-loading washing machines use:

40 to 60% less water

30 to 50% less energy

50 to 70% less detergent

than top-loaders. ▶





Look for the Energy Star

Appliances that receive an Energy Star rating from the U.S. government are among the most efficient available today. They may cost more to purchase, but they will also cost less to operate over the time you own them.

- An Energy Star washing machine may use about a third of the energy and less water than other machines.
- Most Energy Star washers remove more water from your clothes during the spin cycle, so the clothes don't take as long to dry in the dryer.
- An Energy Star refrigerator can save \$35-\$70 a year compared to older models. That adds up to \$525-\$1,050 over the average 15-year life of the unit.
- Energy Star dishwashers use less water and energy, and must exceed minimum federal standards for energy efficiency by at least 25 percent.

Appliances in a Nutshell

- Consider lower-cost cooking alternatives such as toaster ovens and microwaves.
- Know how to read an EnergyGuide label.
- Look for the Energy Star to find highly energy-efficient new appliances.

3 Home Electronics

While individual energy consumption of home entertainment systems, computers and other home electronics may be relatively low, the cost can add up.

Unplug to Save

When you're away from home for the weekend or longer, don't just turn off your TV, DVD player and cable box. Unplug them. As long as these and other small electronics are plugged in, they'll draw power to operate timer displays and other functions that stay on even when the device is switched off. You won't save a fortune—from \$.25-\$3 a month per device—but every little bit counts.

Protect Against Power Surges

This simple step isn't about lowering your electric costs for home electronics. It's about avoiding the big hit you'll take if a power surge destroys your DVD player or other small electronics. Power surges are slight changes in voltage that happen during storms or other electrical events. They can damage the sensitive circuits inside electronic devices. To protect against them, plug your electronics into a surge protector.

Take Advantage of Built-In Computer Features

If you have a computer that runs on Microsoft Windows, use the power management controls to put your computer to sleep after it idles for a specified period (adjustable from five minutes to more than an hour). The hibernation mode reduces the amount of power the computer uses (up to 300 watts at full power) to 15 watts or lower. In addition, some of the newest computers available have a feature called IAPC (Instantly Available PC) that sends the computer into a sleep mode of less than 8 watts—and then allows it to go right back to where you left off instantaneously when you turn it back on.

Microwaving Makes Sense

Reduce your energy bills for cooking by using your microwave instead of your range or oven when you can. Microwave ovens use less energy than traditional appliances, and they don't heat up your kitchen.

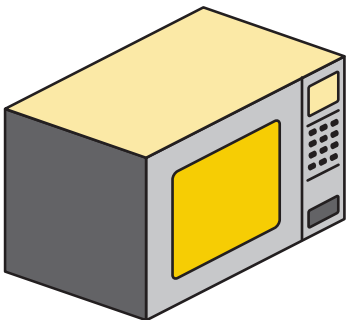



Don't confuse a power strip with a surge protector: A power strip offers no protection from power surges.

Gives New Meaning to "Flat Rate"

Been wanting a sleek, new flat-panel computer monitor—but worried about the high price? Does it help to know they use only about a third of the energy of a traditional monitor? You may pay more for one initially, but the savings over time are likely to make up for that.

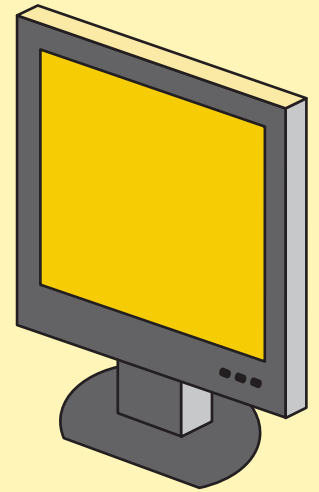

Home Electronics in a Nutshell

- When you're away for extended periods, unplug small electronics.
- Invest in a surge protector to keep power spikes from harming electronics.
- Take advantage of your computer's power management controls.
- Consider a flat-panel monitor for energy savings.

4 Lighting

Go fluorescent. A 25-watt fluorescent light will generate as much light as a 100-watt incandescent bulb for one-fourth the energy. Fluorescent lights cost more to buy, but far less to operate. They last longer, too.

Turn out the lights. Don't waste energy by leaving lights on when you're not using them. Consider installing timers or sensors to reduce the amount of time your lights are on.

Use task lighting. Focus the light where you need it for reading, studying, sewing and other tasks, rather than just brightly lighting the entire room.

Avoid long-life incandescent bulbs. They are the least efficient of all incandescent light bulbs.

Buy fixtures with fewer bulbs. A 100-watt bulb glows with nearly 50 percent more light than four 25-watt bulbs.

Look for the Energy Star. Light bulbs and light fixtures are eligible for the Energy Star rating. Energy Star lighting uses two-thirds less energy and lasts six to 10 times longer than traditional lighting.



Replace 25 percent of the incandescent lighting in high-use areas with fluorescent lighting, and you'll save about 50 percent on the lighting portion of your electricity bill.

Fluorescent lighting is four times more efficient than incandescent lighting. ▶

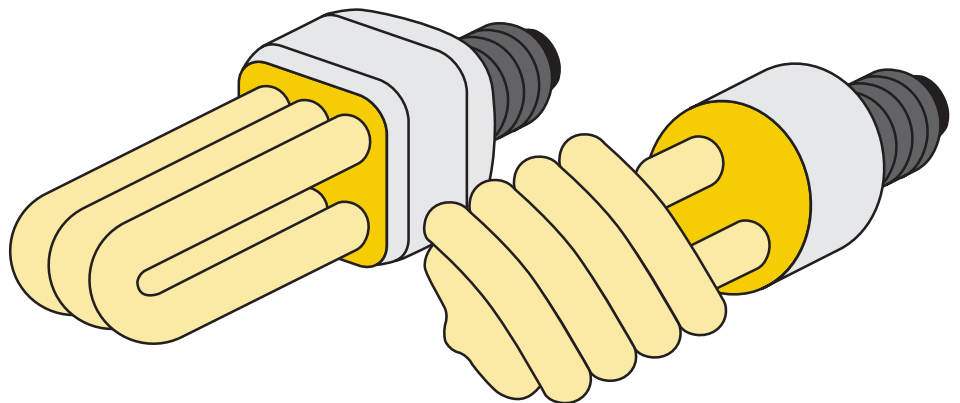

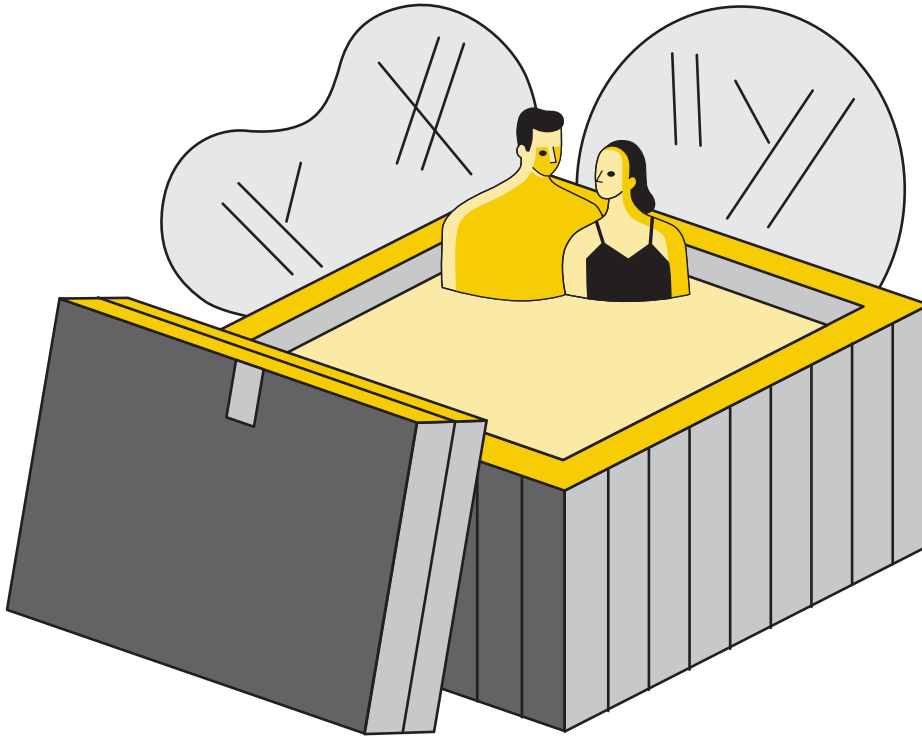

Timers, covers, solar heating, lower temperature settings and insulation reduce the cost of using spas. ◀

5 Pools and Spas

Relaxing in your pool or spa is even more enjoyable when you know it's not costing you a fortune to operate. A few simple steps can make a big difference in the energy cost to heat and circulate the water in your pool or spa.

Use a timer. A timer on the pool pump will make it easier to reduce the running time to only what it takes to keep the water clean and sanitary.

Keep it covered. Cover your spa with a tight-fitting, insulated cover when not in use.

Lower the temperature. Reduce the temperature or turn off the pool or spa heater between uses.

Consider solar heating. It's a much more affordable way to heat your pool than traditional electrical resistance heating.

Look for good insulation. When purchasing a new pool or spa, look for insulation that has been applied directly to the fiberglass or wood that holds the water. This type of insulation reduces heat loss and helps maintain water temperature.

Together, We Can Keep Energy Costs Under Control

Your electric cooperative is dedicated to delivering energy and energy solutions to you safely, dependably and at a reasonable cost. As a co-op member, you have the power to help keep that cost under control. When you use the information in this booklet to use energy efficiently in your home or business, you play an important part in reducing energy demands and controlling your co-op's energy costs. Thanks for taking the time to learn more about action you can take, and thanks for doing your part.

Resources

Air-Conditioning and Refrigeration Institute, www.ari.org

The Alliance to Save Energy, www.ase.org

American Architectural Manufacturers Association, www.aamanet.org

American Council for an Energy-Efficient Economy, www.aceee.org

American Society of Landscape Architects, www.asla.org

American Solar Energy Society, www.ases.org

Association of Home Appliance Manufacturers, www.aham.org

Cellulose Insulation Manufacturers Association, www.cellulose.org

Efficient Windows Collaborative, www.efficientwindows.org

Energy Star, www.energystar.gov

Federal Trade Commission, Bureau of Consumer Protection, www.ftc.gov

Insulation Contractors Association of America, www.insulate.org

National Arbor Day Foundation, www.arborday.org

National Association of Home Builders, www.nahb.org

National Association of State Energy Officials, www.naseo.org

National Insulation Association, www.insulation.org

North American Insulation Manufacturers Association, www.naima.org

Polyisocyanurate Insulation Manufacturers Association, www.pima.org

Rocky Mountain Institute, www.rmi.org

Solar Energy Industries Association, www.seia.org

Solar Rating and Certification Corporation, www.solar-rating.org

Texas Electric Cooperatives, www.texas-ec.org

U.S. Department of Energy's Energy Efficiency and
Renewable Energy portal, www.eere.energy.gov

Window and Door Association, www.wdma.org

